

NOTE: BREAK ALL CORNERS WITH 0.015" (.38 MM) RADIUS UNLESS OTHERWISE NOTED. STANDARD TOLERANCES TO APPLY UNLESS OTHERWISE SPECIFIED.

CUSTOMER PART No.	CAN ART STD.	DIE No. EH05543
DESCRIPTION	1 1/2" x 1" x 0.055" THK. RECT. TUBE	PROPOSAL No. H-6188

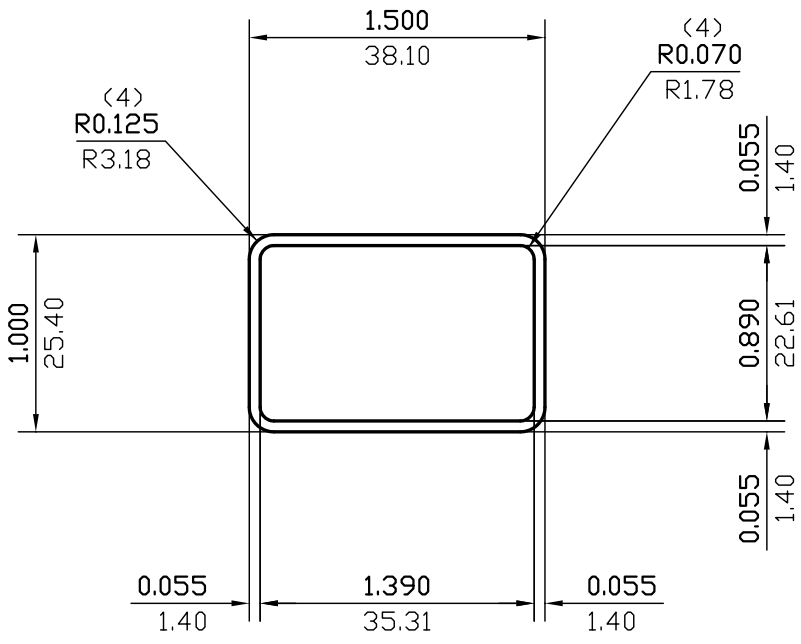

WALL THICKNESS 0.055 (1.40) EXCEPT AS SHOWN

DATE	REV	DESCRIPTION	BY
03/15/23	2	REMOVED ALLOY	JASON
08/10/99	1	REDRAWN	P.M.
EST. AREA	0.254	IN. ²	EST. AREA 164
			MM. ²
EST. WT.	0.304	LBS/FT.	EST. WT. 0.453
			KG/M.
EST. PER.	9.225	IN.	EST. PER. 234.3
			MM.
OUT PER.	4.785	IN.	OUT PER. 121.5
			MM.
C.C.D.	1.701	IN.	C.C.D. 43
			MM.
FACTOR	30	FINISH	M/F
		ALLOY & TEMP.	
CKD BY	SCALE 1:1	DWN BY	C.P. DATE 03/11/97

CAN ART

ALUMINUM EXTRUSION INC.

85 PARKSHORE DRIVE
BRAMPTON, ONT L6T 5M1
TEL. NO. (905) 791-1464
FAX NO. (905) 791-9151
E-MAIL: canart@canart.com

THIS DRAWING IS NOT NECESSARILY A COPY OF YOUR ORIGINAL. PLEASE APPROVE DIMENSIONS AND TOLERANCES INDICATED. CAN ART ASSUMES NO RESPONSIBILITY EITHER TECHNICAL OR LEGAL FOR HAVING THIS SHAPE MADE. THE CUSTOMER AGREES TO FULLY PROTECT CAN ART ALUMINUM FROM CLAIMS OF OTHERS RESULTING FROM THIS SHAPE.

SIGNED: _____ DATE: _____